

## 0. EXECUTIVE SUMMARY

### 0.1 INTRODUCTION

Excavator is a self-propelled crawler or wheel mounted machine, with an upper-structure, capable of a minimum of 360° rotation, which excavates, elevates, swings and discharges material, by the action of a bucket fitted to the boom and arm or telescopic boom, without moving the chassis or under-carriage, during any part of the working cycle, of the machine.

Hydraulic excavator is a multipurpose earthmoving machine, which can perform many duties, in the field, such as digging earth, mining, loading, quarrying, etc., apart from other activities like well-digging, material handling. The excavator is the only "Earthmoving" machine, capable of, working in three dimensions and in all directions.

### 0.2 APPLICATIONS

**Below Ground Level Applications :** The hydraulic excavators can be used (primarily with backhoe attachment) for digging below ground levels. Applications are :

- Canal excavation
- Channel making
- Trench digging
- Pipe laying
- Burrow pit excavation
- Land levelling

**Below or Above Ground Level in Vertical Plane :** These are accomplished by Clamshell attachments. Applications are :

- Well sinking
- Dredging
- Handling of loose materials

**Above Ground Level Applications :** These are mainly done by using a shovel attachment, either bottom dumping, or forward dumping. Applications are :

- Mining
- Quarrying
- Bulk earthmoving against face
- Tunneling

**Under Ground Applications :** These are generally handled by shovel or backhoe attachment or hydraulic hammers. Applications are :

- Tunnel making
- Excavation
- Scaling

**Special Applications :** By using special attachments, a hydraulic excavator can be used for other applications, such as :

- Rock breaking, demolition
- Wood handling (Forestry)
- General construction - vibratory pile drivers, extractors, etc.
- Scrap handling

**Specialised Mounting Applications :** Depending on work requirement, excavator can be -

- mounted on barge and pontoon for swamp, river and marine excavation or dredging operations;
- mounted on railcar for route maintenance activity of railway tracks

### 0.3 INDUSTRY PROFILE

There are six companies engaged in the manufacture of hydraulic excavators :

1. Bharat Earth Movers Limited, Bangalore (BEML)
2. Heavy Engineering Corporation, Ranchi (HEC)
3. Hindustan Motors Limited, Calcutta (HM)
4. Larsen & Toubro Limited, Bangalore (L&T)
5. Stanford Engineering Limited, Delhi (STANFORD)
6. Tata Engineerings Locomotive Co Ltd., Jamshedpur (TELCO).

The study covers hydraulic excavators, manufactured by the above six companies, and M/s Escorts JCB, Ballabgarh (E-JCB), who manufacture Backhoe Loader, which is used, for similar applications, as the excavator. Details of foreign collaborations of these firms out the models manufactured by them are given Table (a) and Table (b) respectively

Table (a) Details of foreign collaboration for Hydraulic Excavators :

	Indian Company	Foreign Collaborator/ Country	Year of Collabo- ration Agreement	Year of Start of Production
1.	BEML	M/s Komatsu, Japan	1982	1984
2.	HEC	M/s O&K (Orenstein & Koppel) West Germany	1984	1986
3.	HM	M/s Mannesmann Demag Baumashines West Germany Also M/s Caterpillar USA	1979  1985	1980
4.	L&T	M/s Poclain S.A. (Now Case-Poclain) France	1973	1975
5.	STANFORD	M/s Franz Eder Maschinenfabri West Germany	1983	1985
6.	TELCO	M/s Hitachi Construction Machinery Co. Ltd. Japan	1984	1985

Table (b) Various Models, Sizes, Options available from Indian Manufacturers

Manufacturer Model	General Operating Parametres							
	Operating Weight Tonnes	Bucket Capacity Range Cu.m.	Rated H.P.	Max. Digging Reach (mm.)		Max. Digging Depth (mm.)		
				Backhoe	Shovel	Backhoe	Shovel	
BEML	PC220-3	22	0.44-1.26	148	10460	2850	7160	2850
	PC300-3	29	0.5-1.8	197	11900	8450	8200	3200
	PC650-3	65	2.9-3.7	404	15070	10135	10330	3530
	PC1600-3	162	9.5	2x410	16450	12600	10000	4050
HEC	RH30-C	61.1	1.8-4.7	301	13800	9900	9200	3100
	RH40-C	82.6	2.0-5.6	330	15600	11200	10400	2500
	RH75-C	120.1	2.6-10.0	589	19000	11400	12200	2200
HM	H-40	38.0	1.32-2.75	212	13200	8200	9200	3500
	H-55	51.5	1.87-3.30	264	1500	9200	11900	4000
	H-85	85.0	4.0-5.0	446	12000	10000	7000	2800
	H-121	113	5.5-11.5	720	13800		8400	
L&T	90CK-II	20	0.83-1.2	115	9200	6600	6150	2700
	90 P	17	0.64-0.95	103	10350	6900	6950	2550
	170 CK	30.5	1.1-2.2	217	11500	7800	7650	4150
	300CK-II	58	2.1-3.0	320	11600	8700	7650	2400
STANFORD	R 825	18.3	0.245-0.995	105	9000	7000	6000	—
	R 835	22.0	0.52-1.610	135	9800	7200	6500	2500
TELCO	UH 083LC	20	0.4-1.20	110	9850	7200	6650	2500
	UH 181	41	1.36-2.28	250	11970	8770	7730	4280
	UH 261	60	1.89-3.50	2x175	13730	9640	8780	4570
	UH 501	90	2.90-4.90	2x250	13700	11000	7770	5190

#### 0.4 POPULATION

The approximate distribution, of the total population, of machines sold by various manufacturers and their region wise distribution, is given in table (c).

Table (c) Population Statistics Manufacturer wise &amp; Region wise.

Manufacturer	Total Units Sold Till 31-3-88	Region wise Distribution			
		North	South	East	West
BEML	258	22	44	109	80
HEC	21	4	1	9	7
HM	132	17	28	36	51
L&T	1052	210	259	275	308
STANFORD	94	15	18	34	27
TELCO	365	80	90	125	70
<b>TOTAL</b>	<b>1922</b>	<b>348</b>	<b>443</b>	<b>588</b>	<b>543</b>

Source : Compiled from data received from manufacturers.

### 0.5 SALES & PRODUCTION

Size wise sales and production data of hydraulic excavators for the period 1984-88 is as under :

Class of Machine (bucket capacity)	Number of Units Sold/Produced During the Year							
	1984-85		1985-86		1986-87		1987-88	
	S	P	S	P	S	P	S	P
S <sub>1</sub> (0.6-1.1 cum)	114	117	212	217	237	235	203	220
S <sub>2</sub> (1.2-1.9 cum)	-	-	-	-	-	-	15	15
M <sub>1</sub> (2.0-3.0 cum)	16	9	20	25	56	44	37	49
M <sub>2</sub> (3.0-4.0 cum)	65	74	112	116	68	81	74	73
L <sub>1</sub> (4.0-6.0 cum)	-	-	3	3	6	6	4	4
L <sub>2</sub> (6.0-12 cum)	-	-	-	-	3	3	-	-
<b>TOTAL</b>	<b>195</b>	<b>200</b>	<b>347</b>	<b>367</b>	<b>370</b>	<b>374</b>	<b>333</b>	<b>361</b>

Source : Compiled from details received through questionnaire & personal visits.

S - SALES  
P - PRODUCTION

**0.6 DEMAND FORECAST**

Demand forecast, for hydraulic excavators, for the year 1990 to 1995, is given in the following table. The demand, figures, are average values. There may be some fluctuations, depending upon the state of the economy.

Class of Machine	Bucket Capacity Range Cu.m.	Gross Weight Range Tonnes	VIIIth Plan Period (1990-95)				
			1990-91	1991-92	1992-93	1993-94	1994-95
S1	0.6-1.1	18-22	270	290	315	330	350
S2	1.2-1.9	23-30	25	30	35	40	45
M1	2.0-3.0	32-45	45	45	50	55	60
M2	3.0-4.0	54-65	103	108	110	110	120
L1	4.0-6.0	70-95	28	32	40	50	50
L2	6.0 and above	above 95	4	5	5	10	10
Total			475	510	555	595	635

0.7 TECHNOLOGY STATUS - INTERNATIONAL LEVEL

0.7.1 Worldwide Sales

Sales of all type of construction machines worldwide, excluding comecon countries, is as follows :

Product Group	1982 A		1987 B		Increase 1982-87 (B-A)/A Percentage
	U.S.\$ Billion	% of T.D.	U.S.\$ Billion	% of T.D.	
1. Wheel Loaders, Dozers, backhoe- Loaders, Skid Steer Loaders	5.25	27.4	6.95	26.1	32%
2. Hydraulic Excavators	3.88	20.2	6.57	24.7	69%
3. Bulldozers, Crawler Loaders	3.27	17.1	3.88	14.6	19%
4. Road Rollers and Compactors	1.70	8.9	2.32	8.7	36%
5. Compressors	1.03	5.4	1.26	4.7	22%
6. Dump Cars	1.01	5.3	1.43	5.4	41%
7. Hyd. Cranes/ Rough Terrian Cranes	1.01	5.3	1.39	5.2	38%
8. Crawler Cranes, Truck Mounted Cranes	0.92	4.8	1.27	4.8	38%
9. Others	1.09	5.6	1.53	5.8	40%
Total Demand (T.D.) U.S. \$ Billion	19.16	100.0	26.60	100.0	Average 38%

Source : EIU Report

Sales of major types of construction machines by numbers is as follows :

Type of Equipment	1982* (A)	1987** (B)	Increase (B-A)/A Percent
Hydraulic Excavator	42,600	62,400	46%
Crawler Cranes	2,220	2,350	6%
Wheel Loaders	43,400	55,510	27%
Bulldozer	31,340	37,490	20%

\* Source : EIU Report

\*\* Estimate of construction machinery magazine reports

### 0.7.2 Worldwide Demand

Breakup of worldwide demand by numbers, except for comecon countries, (Bucket Capacity 0.2 Cu.m. and above) for hydraulic excavators is given in the following table :

Territory	1982* (A)	1987** (B)
Japan	23,900	35,800
Europe	11,200	11,075
North America	1,700	9,415
Asia and Far East (excl. Japan and India)	1,700	2,738
Africa	950	818
Middle East	2,200	1,076
Oceania	600	876
Central and South America	350	602
Total	42,600	62,400

\* Source : EIU Report

\*\* Estimated from magazine reports.



## 0.8 OVERALL VIEW OF THE HYDRAULIC EXCAVATOR INDUSTRY

### 0.8.1 Manufacturers and Products

Out of the six companies, two are large undertakings (BEML & HEC), three are large public limited companies, belonging to big industrial houses (HM, L&T and TELCO) and one (Stanford) is medium size public limited company, which started, its, activities with manufacturing of hydraulic excavators only. All the companies except STANFORD are covered under MRTP Act.

The companies (HEC, HM & STANFORD), have collaborations, with West German companies and two companies (BEML & TELCO), have collaborations, with Japanese companies. While one company (L&T), has collaboration, with French company, Escorts-JCB have collaboration with British Firm.

There are 21 models, of the hydraulic excavators, manufactured by the six manufacturers, either, with backhoe bucket or with shovel. The bucket capacity, for backhoe, ranges from 0.91 to 7.8 Cu.m. and for shovels from 0.5 to 12.0 Cu.m. They offer selected range of booms and arm combinations.

The licenced capacity, for the hydraulic excavators products line, only, cannot be established, as under the Government's broad categorisation, all types of earthmoving machines have been grouped and classified under one group and the licenced capacity, of all the manufacturers, has been re-endorsed as under :

Earthmoving machinery including Bulldozers, Dumpers, Scrapers, Loaders, Vibratory Compactors & Draglines (excluding walking draglines).

Since some of the manufacturers, also manufacture other types of earthmoving machines, capacity of the individual type machine cannot be established.

As per the report of VII Plan, the sub-committee on earthmoving equipments, the licenced capacity for various types of excavators during VII Plan period is 575.

The actual production in numbers for the last few years is as under :

	1984-85	1985-86	1986-87	1987-88
Numbers Sold :	200	367	384	361

### 0.8.2 Technology Absorption

All, but one of, the manufacturers are in the engineering industry, for a very long period and have absorbed the imported technology very effectively.

### 0.8.3 Research & Development

All units have, reported, in-house R&D facilities with the following objectives :

- Absorption of collaborator's knowhow for local manufacture.
- Modification of foreign knowhow to suit local manufacturing process and customer's requirement.
- Maintaining cost competitiveness through value engineering.
- Providing support facilities to plant for prototype, pilot testing and in some cases, quality assurance.
- Development of computer aided designing and manufacturing, as well as, testing facilities.
- Development of new models from concept level upwards.
- To build, progressively, base for the design, development and testing of hydraulic excavators and other earthmoving equipment for specific size, range and application.

While R&D facilities of BEML, HM, L&T and TELCO are fairly large with substantial capital investment in material testing laboratories, structural testing labs, hydraulic components test benches etc. and have well qualified manpower, Stanford has made beginning in engaging some technical personnel.

R&D facilities of BEML, HM, L&T and TELCO are recognised by DSIR. On an average, between 1-1.2% of turnover is spent on R&D efforts.

### 0.8.4 Ancillary Industry

#### DIESEL ENGINE

Though, very, wide capacity range of diesel engines are being produced in the country, the range of engines available for industrial applications is small. The manufacturers, of the hydraulic excavator, in particular, and industrial machinery in general, either uprate or derate various standard engines available from any one of the manufacturers and use the same on the IV machines. In some cases, engines used are vehicular type, modified to industrial applications, but this, does not really transform the engine, to the class of engines, required for excavator duty cycle.

Further, from the data of foreign make engines and locally manufactured engines, it is observed that engines manufactured in India are not, as much, fuel efficient, as the foreign make engines. In higher capacity engine (above 150 KW), only, Kirloskar Cummins are manufacturing diesel engines, for industrial applications.

New entrants, having collaboration with world renowned companies for fuel efficient engines, should be encouraged to introduce their range at the shortest possible time. This will set a healthy trend in the improvement of existing manufacturers. Indian manufacturers are, also, ready to meet the special requirements, called for, by the excavator manufacturer but this require further interaction between user and manufacturers, as well as, intensive research and development work, at the end of diesel engine manufacturers.

#### **0.8.5 Hydraulic Components**

Five, out of six excavator manufacturers are importing hydraulic components from their respective collaborators. The components of one manufacturer are not adaptable by the other and no standardisation has been done except for the mounting flanges, shafts etc. For hydraulic cylinders, Usha Telehoist and Wipro are able to meet quality requirement and cost objective of excavator manufacturers.

#### **0.8.6 Under-Carriage and Track Parts**

Technology available is quite in-line with the advanced technology, available, abroad.

#### **0.8.7 Exports**

Few hydraulic excavators have been exported so far.

#### **0.8.8 Standardisation**

The standardisation is done by the sectional committee of Bureau of Indian Standard (BIS): Bulk Handling Equipment Sectional Committee: EDC:84.

## 0.9 TRAINING

The following table shows the equipment manufacturing companies:

S.No.	Company	Training Programmes Organised for		Location of Training Programme	
		Operator	Mechanics	User's Site	Company's Trg. Centre
1.	BEML	Yes	Yes	Yes	Yes
2.	HEC	Yes	Yes	Yes	No
3.	HM	Yes	Yes	Yes	Yes
4.	L&T	Yes	Yes	Yes	Yes
5.	Stanford	Yes	Yes	Yes	No
6.	TELCO	Yes	Yes	Yes	Yes
7.	ESCORTS-JCB	Yes	Yes	Yes	Yes

## 0.10 CONCLUSIONS & RECOMMENDATIONS

### 0.10.1 Conclusions

- i. There are six companies manufacturing hydraulic excavators. Out of the six, five companies, namely BEML, HEC, HM, L&T and TELCO are large business groups and are covered under MRTP. Only Stanford is medium size company.
- ii. All the, six, companies have foreign collaborations (3 with West German, 2 Japanese and one French).
- iii. There are 21 models, of the hydraulic excavators, manufactured by the, six, manufacturers either with backhoe bucket or shovel. The bucket capacities of the backhoe ranges from 0.91 to 7.8 Cu.m. and for the shovels from 0.5 to 12.0 Cu.m.
- iv. The production and sale of the hydraulic excavator had a spurt in the year 1985-86, when from 200 units, in the year 1984-85, manufacturers went upto 367 units in the year 1985-86. Since then the demand has shown stagnating, trend, at around 375 units.

- v. Total population of indigenously manufactured excavators, upto March 1988, was 1922 with present replacement value of, over Rs.625 Crores.
- vi. The installed capacity is around 575 units.
- vii. The demand forecast shows, that with present level, of Government investments, the present installed capacity is adequate, to meet the demand of the sizes of machines, currently manufactured by the six manufacturers, till the end of VIII Plan period.
- viii. The market of the hydraulic excavator is oligopolistic in nature; but the spare parts, being exclusive to each manufacturer, are priced very high on monopolistic pattern.
- ix. Technology acquired, in the field, is from the world renowned manufacturers.
- x. All the companies, except HEC, have adequately absorbed and adapted the technology to suit local raw material and customers needs. However, except two companies, namely L&T and TELCO, no other company has acquired the know-why capabilities. Most of the manufacturers will continue to import technology for future products. Even L&T and TELCO prefer to go for foreign collaboration so as to avoid the risk of high cost of development for the low volumes of demand.
- xi. All the companies have in-house research and development department which is either a full fledged department or an extension of product engineering department which is supposed to develop new products/ technologies but at this stage, the same is being utilised for technology absorption and to a very limited extent for development of new products and technologies.
- xii. The indigenous, engines used, on the hydraulic excavators, are not meeting the life expectancy and are one of the main causes of service/ field problems.
- xiii. Hydraulic components like pumps, valves, cylinders, filters are being imported by five, out of six, manufacturers; only L&T manufactures these products indigenously. Others are importing the components from their respective collaborators.
- xiv. It is the hydraulic circuit design and hydraulic component, used, which decides quality and operational efficiency of the excavators. Every foreign collaborator has his own (mostly patented) concept and in most cases the collaborators use proprietary hydraulic components. This

forces the Indian licencees to use only the components, which are exclusive, to their collaborators. Therefore, standardisation has not been achieved.

- xv. Due to the above reason, the low volumes of hydraulic components, of each make, do not justify high capital investment, required for indigenisation of the hydraulic components. However, in respect to hydraulic cylinders, most companies are indigenising through existing cylinder manufacturing units, namely Usha Telehoist, Wipro (Fluid Power Division).

As mentioned above, all the manufacturers except L&T are importing hydraulic components from their respective collaborators. This is resulting in out go of huge amount of foreign exchange. It is essential the components particularly the hydraulic elements should be standardised by different manufacturers so that economy of scale permit their indigenisation.

- xvi. For under-carriage and trackparts, technology available with local manufacturers is adequate to meet the requirement of almost all makes of machines.
- xvii. All the manufacturers are concentrating on meeting local demand. Export sales are almost negligible.
- xviii. The training facilities, specially for the training of operators and mechanics for this type of machine are not adequate.
- xix. The standardisation efforts are restricted only to standardisation of terminology, bucket capacities and general parameters. Performance certification is not being done.

However, there is strong need for standardisation of components and sub-system to avoid continuous out go of foreign exchange.

- xx. Prices of spare parts are high and in particular, imported components are priced very high and have long delivery period.
- xxi. Industry has matured and will continue to grow with the need of increasing productivity in mining sector, as well as, building a national irrigation and water distribution network, construction and infrastructure base for the growth of the country.

## 0.10.2 Recommendations

- i. As there are already 6 units manufacturing hydraulic excavators with a combined production of 375 units per annum, which is small compared to international standards. No new manufacturer need be encouraged during the VIII Plan period. The existing manufacturers may be allowed to introduce new models with indigenous/foreign knowhow, but with much higher indigenous contents, right from the start.
- ii. National Development Council for earth moving machinery constituted by DGTD, should identify specific components, like bucket capacity, engine performance parameters, operation cycle time, total digging/excavator efficiency etc. of different models produced by various manufacturers which should be confirmed by performance evaluation at an autonomous test house.
- iii. The manufacturers of hydraulic components, are required to pay normal custom duties, on imported raw materials and components, which is in most cases more than twice the duty being paid on imported, fully finished, products (hydraulic components), by the hydraulic excavator manufacturers (eligible for duty concessions); thus resulting in unfair competition. This has, in turn, prevented manufacture of hydraulic components from indigenising manufacturing of hydraulic components; used on excavators, even though, in some cases, their collaborators do have suitable components for these applications.

Therefore, the import duty anomalies, for hydraulic components, which exist, when components are imported, as part of earthmoving machinery and otherwise part of phased manufacturing programme (PMP), by the hydraulic component manufacturers, should be rectified.

- iv. Currently, the cost of spare parts, for construction equipments, is high irrespective of indigenised or imported. Manufacturer should indigenise spares, at faster rate and reduce the prices. Duty reduction on imported spare parts should be linked up with performance in the indigenisation part.
- v. New manufacturers of fuel efficient and cost effective engines should be encouraged to launch their products in the shortest possible time. Also, technology support should be given to, existing, engine manufacturers, for upgrading their technology, for fuel efficient and cost effective engines.
- vi. All the manufacturers should be encouraged to increase export, of their products, to other countries. In this connection incentive schemes such as Cash Compensatory Support (CCS), International Price Reimburse-

ment Scheme (IPRS) should be streamlined to ensure optimal use of these supports for increasing exports.

CCS and IPRS entitlement should be linked with minimum value addition and also should proportionately be higher for those units which have higher value addition in products exported by them. Besides duty draw back, CCS, IPRC and Rep. Licence Support on value addition, some more export benefits be given, so that manufacturers can make their products competitive in the international market.

- vii. Hydraulic excavators should be included as an item for export under "Bilateral-trade-Agreements" and other government to government purchases. However, the exporting Government agency should inform all the manufacturers of hydraulic excavators about such orders and also keep all the manufacturers in consideration irrespective of demarkation on being public sector or private sector units for such kind of bi-lateral trade.
- viii. Concept of construction equipment leasing has not caught up in the country. This exists at best in the area of material handling and building construction. This concept should be encouraged to ensure usage of modern equipment in construction projects.
- ix. BIS and other agencies put together should standardise, not only, equipment parameters but also the formats of equipment specifications by manufacturers.
- x. A status of technology study on following may be undertaken:
  - a. Dump Trucks, Loaders and other range of earthmoving construction machinery; and
  - b. Fluid Power Industry.



# 1. HYDRAULIC EXCAVATOR - PRODUCT PROFILE

## 1.1 INTRODUCTION

Excavator is a self propelled crawler or wheel machine, with an upper structure, capable of a minimum of 360 degrees rotation which excavates, elevates, swings and discharges materials, by the action of a bucket fitted to the boom and arm or telescopic boom, without moving the chassis or under-carriage during any part of the working cycle of the machine (IS:12138-1987).

Excavators are primary earthmoving machines and equipments used to excavate earth and related materials and to lift items frequently used in construction operations. They are called by different names and put to different uses, depending upon the implements and attachments required. Excavator comprises of fair basic machines namely backhoe, shovel, dragline and clamshell. All four are manufactured in India, alongwith the necessary implement and attachments. They are made of various sizes and capacities to suit the need for light, medium or heavy duty applications where as backhoe and shovels may be either hydraulic or mechanical, the draglines and clamshells are only of the mechanical type.

Hydraulic excavator is a multi-purpose earthmoving machine, which can perform many duties in the field such as digging earth, mining, loading, quarrying etc., apart from other activities like well-digging, material handling the excavator is only "earthmoving" machine capable of working in three dimensions and in all directions. Unrivalled versatility, is the main reason, for hydraulic excavator's domination, of today's world construction equipment scene. Thirty five years ago, when the hydraulic excavator was first introduced in Europe, it was considered as an agricultural loading tool, but today, it can perform functions frames from pile-driving to hedge trimming, often, just as efficiently as purpose built equipment.

## 1.2 BACKGROUND TO STUDY

1.2.1 After independence, through successive five year plans, India launched a massive programme of economic development. Each plan progressively increased emphasis on development of industry, agriculture and infrastructure base like power, transport, communication, etc. To meet the needs of growth of agriculture, massive irrigation schemes have been undertaken. Also, to meet demand of coal by the power sector and industry, more productive machines have been deployed in the mining sector.

In the seventh Five Year Plan (1985-90), emphasis has been placed not only on growth of various core sectors of the economy but also on increasing the productivity, improved utilisation of capital investment, thereby reducing the

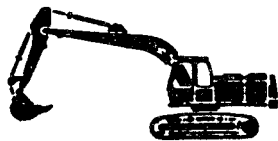
cost of goods and services produced one of the major weakness that has emerged in the Indian economy, is low productivity, resulting from several inter-related factors. One cause of low productivity is the inefficiency in the use of capital, the cost of creating infrastructure facilities by Government department/agencies has often been raised in the past because of delays in the implementation and insufficient attention paid to efficient management and to the adoption of cost effective methods, improvements in capacity utilisation and efficient project implementation in all areas, especially in irrigation, power, transport and industry.

Excavator has principal applications in construction, mining and irrigation and land development. All these sectors have substantial allocation of resources by centre, as well as, state during the seventh plan period. In coal mining, the present pattern has been approximately 42% underground and 58% opencast.

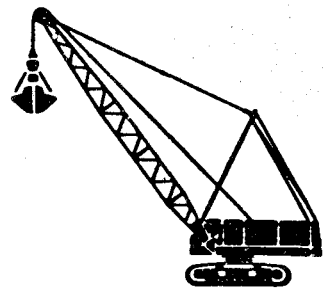
The earthmoving industry is the complex mix of various types of equipments. The growth in individual item is not likely to be common or uniform in all sections. The demand in terms of numbers would undergo a change qualitatively due to larger sizes being acquired by project authorities. For example, excavators/shovels in the range of 4-5 cu.m. capacity were common in Vth/VIth plans, but as per the indications of coal sector, these are to be upgraded to 8-12 cu.m. capacity and even to 20 Cu.m capacity. This would naturally be a great boom to the earthmoving industry and in particular for hydraulic excavator/shovels.

### 1.3 HYDRAULIC VS. MECHANICAL EXCAVATORS:

In a mechanical excavator, power transmission and control is achieved with the help of mechanical components such as friction drives, gear drives, clutch and brakes. These components, for high capacity power transmission, result in bulky size machines. In hydraulic excavator, power transmission is achieved through hydraulic oil medium, which gives much higher power, transmitted to weight ratio and higher controllability and safety capabilities for the machine elements. Apart from this, there are many, application, advantages of hydraulic excavator over a mechanical excavator. Following is the comparison of relative merits of the two types of excavators:



Hydraulic Excavator



Mechanical Excavator

## Hydraulic Excavator

- i. Exerts very high breakout forces, leading to reduction or elimination of prior loosening.
- ii. The bucket can be rotated with respect to the stick (arm) by means of hydraulic cylinders. And this gives powerful prying out action.
- iii. Requires very little very few parts exposed to wear and all hydraulic components are self lubricated. Larger models are equipped with automatic centralised lubricating system which ensures proper lubrication in quantity and at regular intervals.
- iv. Due to the high pressure hydraulics the components used are smaller and the overall dimensions of the machine are reduced. This reduces the dead weight of the machine considerably and the ground bearing pressure, thereby ensuring efficient operation even in very poor ground conditions.
- v. Both the bottom dump and forward dump loader bucket can be used (higher models).
- vi. Since the bottom dump bucket is opened hydraulically, it provides a metered discharge to minimise shock loading to haulers.
- vii. Can handle bigger boulders than the bucket since the bottom dump bucket can also be used as a forward dump bucket.
- viii. Can take a number of attachments to perform a wide variety of operations.

## Mechanical Excavator

Exerts much lower breakout forces.

Features a bucket which is rigidly fixed to the stick. Hence there is no wrist action.

Needs more maintenance, since the system is mechanical. There are more than 120 grease nipples to be greased every 10 hours of operation.

The dead weight of the machine is more\* and has a much higher ground bearing pressure than a hydraulic excavator of comparable capacity thus restricting its area of operation.

(\* The dead weight is almost double of comparable size of hydraulic excavator).

Only bottom dump loader bucket can be used.

The bucket is opened mechanically, therefore the contents are just dropped into the haulers. This shock loads the hauling units.

Has limitations in rock handling since bigger boulders may not find their way through the bottom opening.

Has limited applications.

- |       |   |   |
|-------|---|---|
| ix.   | Has a very high gradeability.   | Has much lower gradeability.  |
| x.    | Simple Hydrostatic transmission, eliminating clutch, transmission and reduction gears.                      | Transmission is very complex, clutches, transmission brakes, pulleys, winches, cable and chain drive etc. |
| xi.   | The smaller models can be mounted on wheels to provide site to site mobility.                               | Cannot be mounted on wheels.  |
| xii.  | Has much higher travelling speed.   | Travelling speeds are low.  |
| xiii. | Two joy-stick controls, facilitate easier operation.  | The operator has to operate about 7 controls, 4 hands and 3 pedals.                                       |
| xiv.  | Crawlers are hydraulically driven and can be counter rotated, facilitating the machine to turn on the spot. | Crawlers are mechanically driven and can be operated simultaneously in one direction only.                |

## 1.4 HYDRAULIC EXCAVATOR PRODUCT DESCRIPTION

### 1.4.1 Components :

A typical hydraulic excavator is shown in Fig. 1. Its major components are under-carriage, upperstructure and front-end attachment(s) consisting of boom, arm and bucket.

1. Under-carriage
2. Upper Structure
3. Boom
4. Arm
5. Bucket

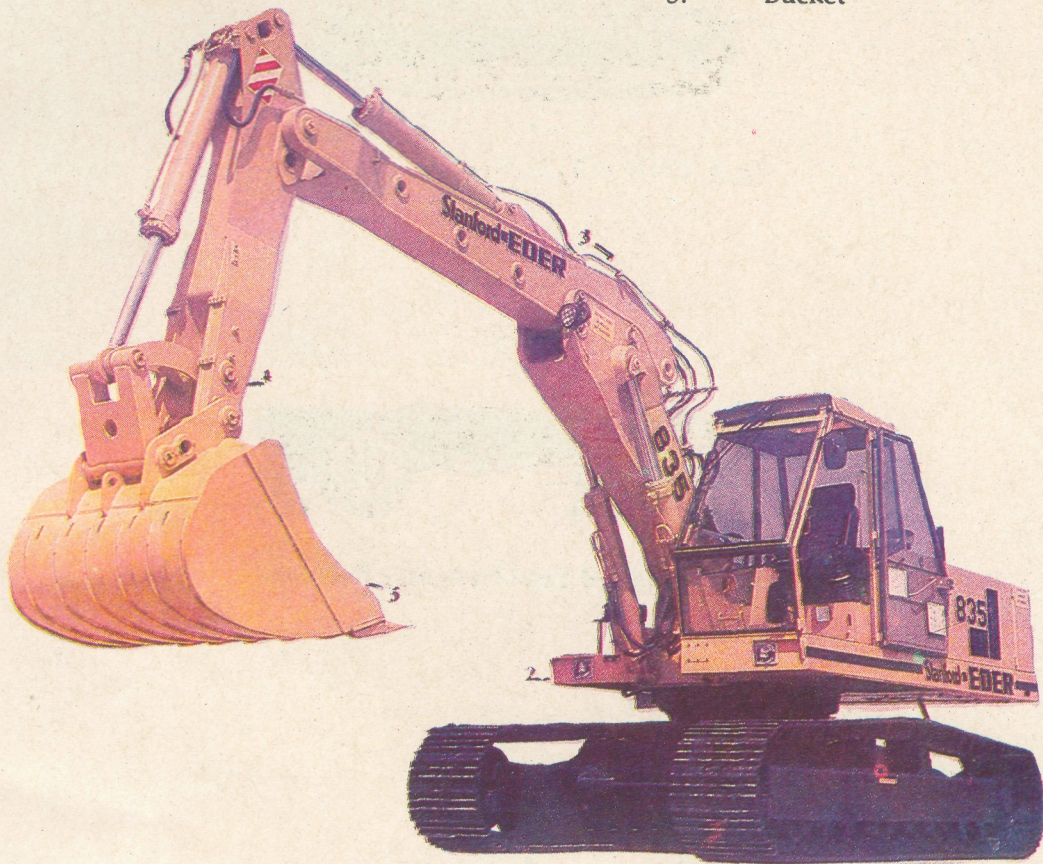
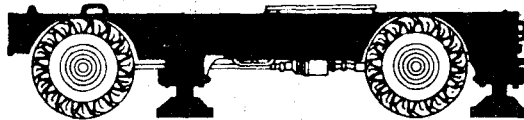


Fig. 1 : Components - Hydraulic Excavator

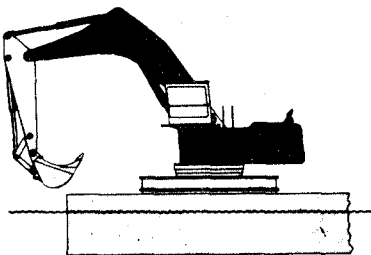
**Under-Carriage :** It is the lower portion of the excavator on which the equipment travels. It could be either crawler or wheeled type or fixed mount type as shown in Fig. 2, 3 and 4 respectively.



**Fig 2 : Crawler Type Hydraulic Excavator**

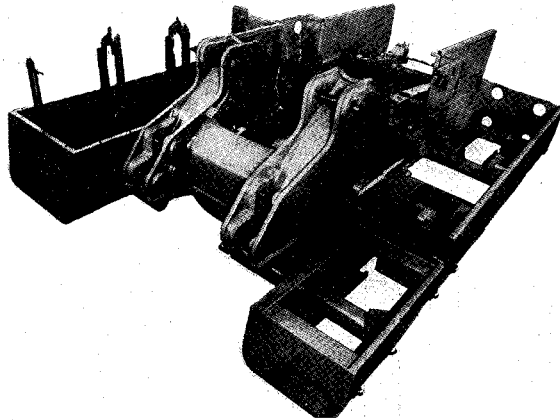


**Fig 3 : Wheeled Type Hydraulic Excavator**

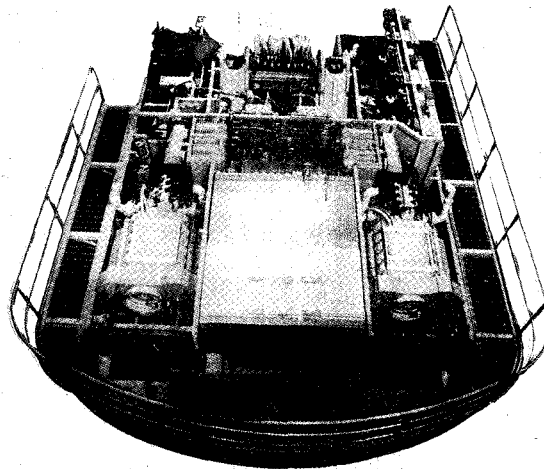


**Fig 4 : Fixed Mount Type Hydraulic Excavator**

**Upper-Structure :** Upper structure of a hydraulic excavator which consists of primemovers, hydraulic systems components, operator's cabin and controls, etc. and forms the upper portion of an excavator, which can rotate by 360 degrees in either direction with respect to the under-carriage. Fig. 5 shows details of a typical upper-structure of a hydraulic excavator.



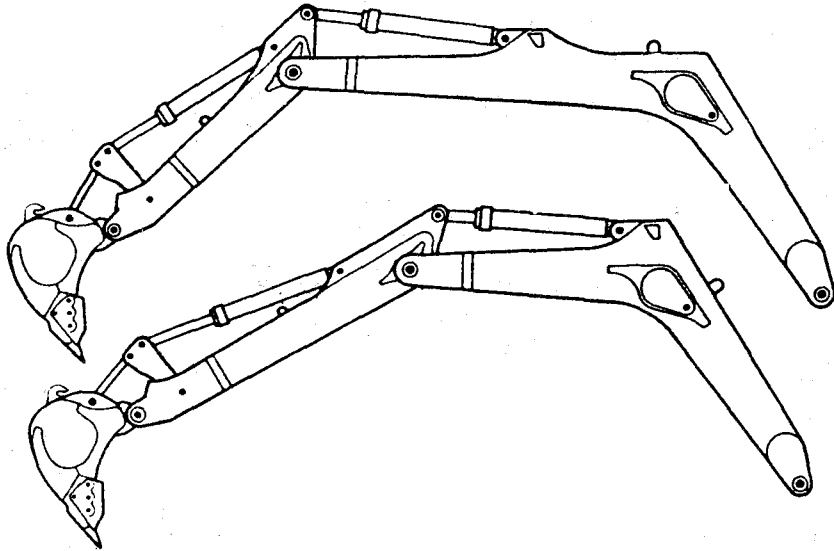
**Fig. 5a**



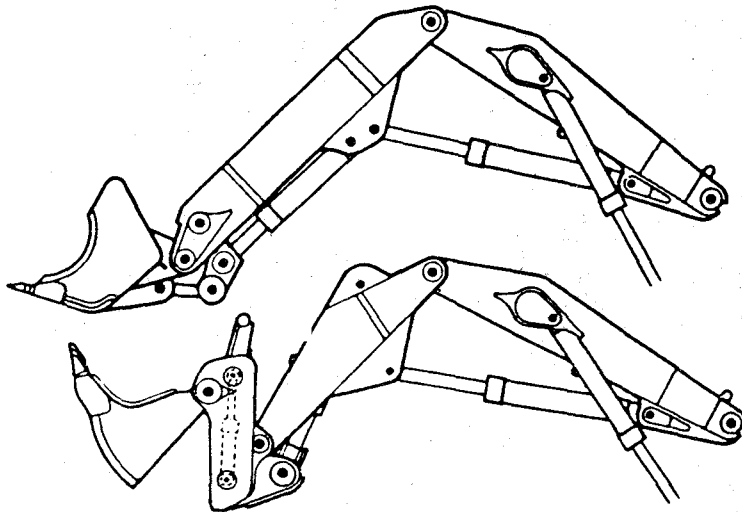
**Fig. 5b**

**Fig. 5a&b : Upper-Structure of a Hydraulic Excavator**

**Front-end-attachments** : The component of excavator, which does the actual work of digging/loading/trenching, etc. and consists of boom(s), arm and bucket, is attached to the upper-structure. Fig. 6 and 7 show front-end-attachments for a backhoe and shovel type hydraulic excavators.



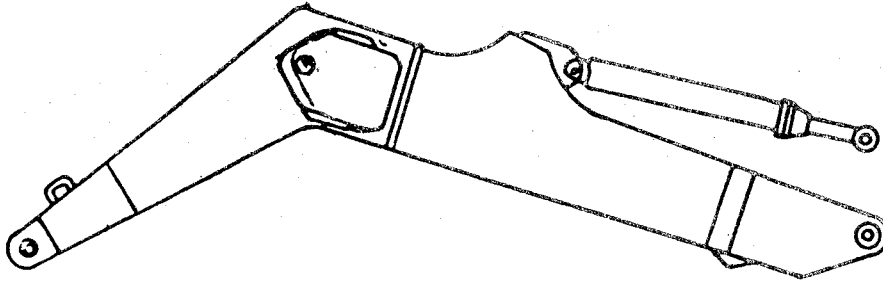
**Fig. 6 : Front-end-attachment for a Backhoe Type Hydraulic Excavator**



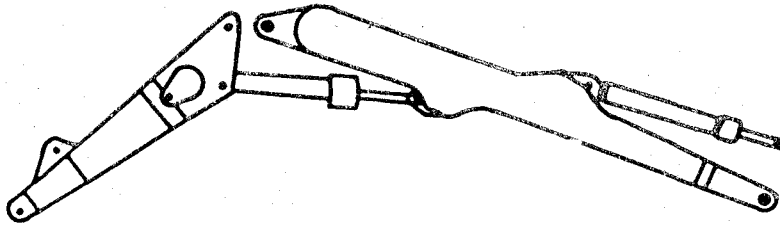
**Fig. 7 : Front-end-attachment for a Shovel Type Hydraulic Excavator**



**Boom** : The first limb of attachment which is hinged to the upper structure. This can either be one piece (monoblock or as is called "Gooseneck" type) Fig. 8 - or two pieces. Designs of booms differ depending upon whether the attachment is backhoe, shovel or any other. Further in two piece booms, there can be a provision for varying the length of boom, which gives many operational advantages.



**Mono Block Boom**



**Two Piece Boom**

**Fig. 8 : Mono Block and Two Piece Boom**

**Arm** : The second limb of attachment which is hinged on one end to the boom and on other end to the bucket. Design differs depending upon attachment.

**Bucket** : This is the component of hydraulic excavators which digs into earth and gets filled with material. The construction of bucket differs depending on the work requirement.

**Backhoe** : The attachment which is used mainly for digging below ground level. Fig. 9 shows a backhoe type hydraulic excavator.

**Shovel** : The attachment which is used mainly above ground level against a face or heap of material. Fig. 10 shows a shovel type hydraulic excavator.

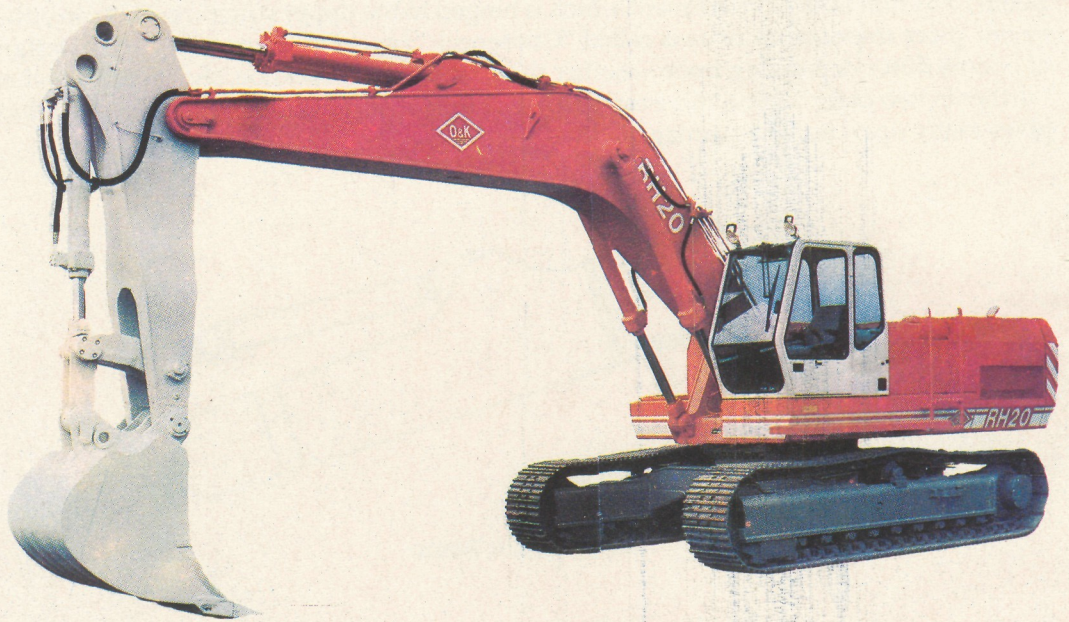


Fig. 9 : Backhoe Type Hydraulic Excavator

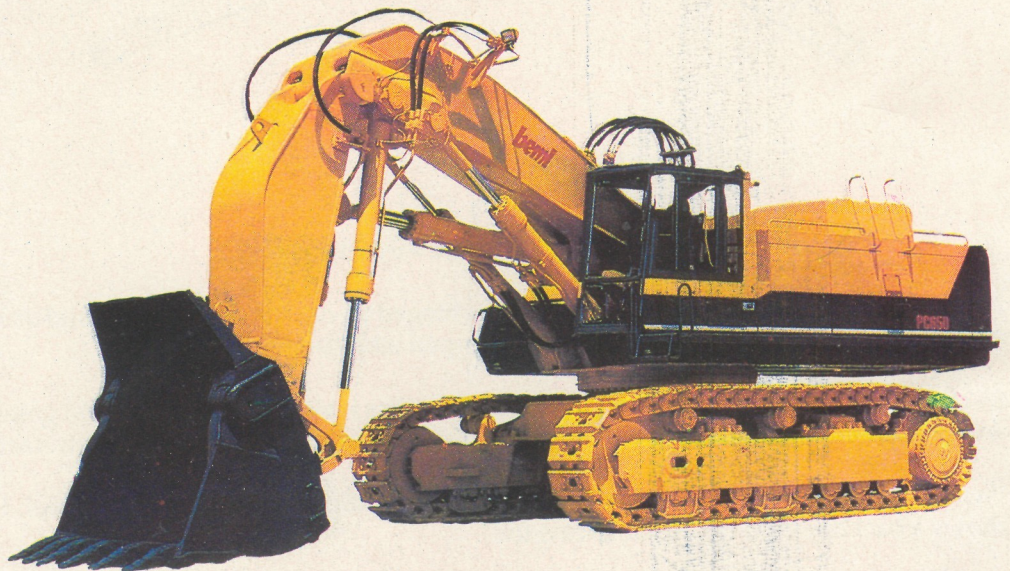


Fig. 10 : Shovel Type Hydraulic Excavator

## 1.4.2 Operational Principles :

Fig. 11 explains operational principle of transmission of power through component of hydraulic excavator for accomplishing required output function.

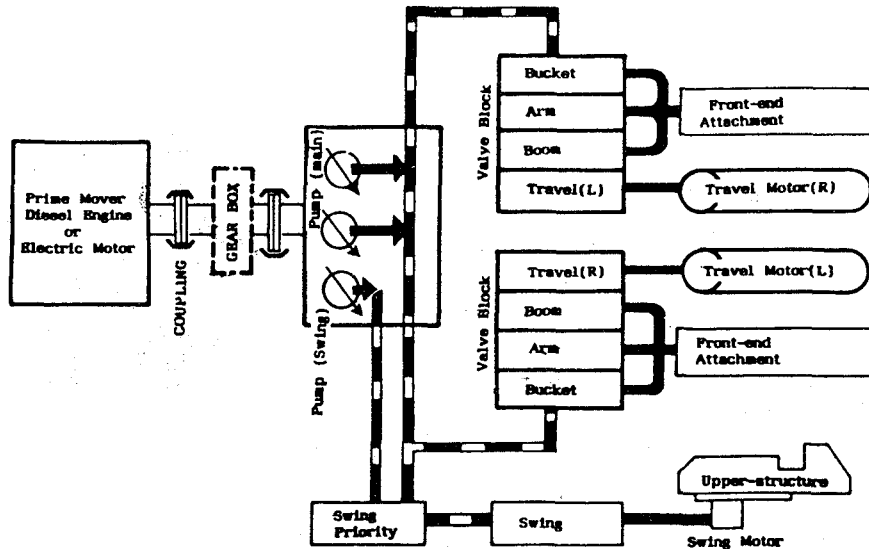


Fig. 11 : Principle of Transmission of Power

Mechanical energy is transmitted from the prime-mover (which could be an electric motor or a diesel engine) to hydraulic energy by the pump(s). The flow of the oil generated by the pump(s) is passed through control valves to the output devices such as hydraulic cylinders (which cause relative movements of boom, arm and bucket with respect to each other and to the upper-structure) and/or hydraulic motors (for swing of the upper-structure with respect to the under-carriage and travel of the equipment on the ground) and for other auxiliary functions.

In order to achieve effective transmission of power and control functions required for the operation of the machine, special hydraulic circuits are incorporated, which give optimum use of hydraulic energy and have safety features for components, thereby reducing losses to minimum and giving better efficiencies through :

- good utilisation of installed horsepower;
- coordination of simultaneous and sequence work operations;
- regeneration of operator's comfort with regard to automation of control sequences, simplified controllability etc.

Hydraulic circuit is the key to the design of a hydraulic excavator and design concepts varies from manufacturers to manufacturers (see chapter 5 for details).

#### 1.4.3 Attachments

Fig. 12.1, 12.2 and 12.3 give some of the basic attachments which are commonly used on hydraulic excavator. These are only a few illustrations of various types of attachments, which are available. Depending on the application and material to be handled, combination of boom, arm and buckets can be different.

#### 1.5 APPLICATIONS OF HYDRAULIC EXCAVATORS :

As stated in the previous chapter, a hydraulic excavator is the most versatile construction machine. The excavator is the only "earthmoving" machine, capable of working in three dimensions and in all directions. It can lift, lower, push, pull and side shift at, above, and below ground level and in a full circle, without having to move its under-carriage. The wheel loader, by comparison, can work only at ground level and above and at severally limited reach, the scraper and the bulldozer are restricted to the horizontal plane at ground level, and the tractor-mounted backhoe, even ignoring its severe size restrictions, is effective through less than half a circle.

The following are applications for hydraulic excavator :

##### Below Ground Level Applications :

The hydraulic excavators can be used (primarily with backhoe attachment) for digging below ground levels. Applications are :

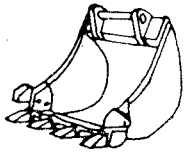
- Canal excavation,
- Channel making.
- Trench digging.
- Pipe laying.
- Borrow pit excavation.
- Land levelling.

**Below or Above Ground Level in Vertical Plane :**

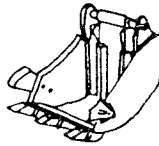
(These are accomplished by Clamshell attachments.)

Applications are :

- Well sinking
- Dredging
- Handling of loose materials.



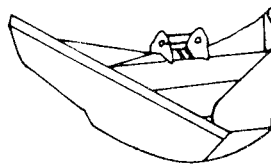
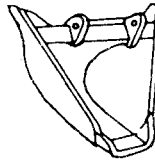
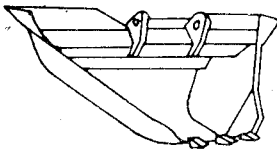
**Backhoe Earthmoving Buckets**



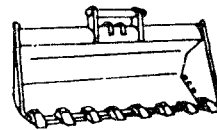
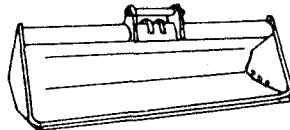
**Backhoe Buckets with Ejector Blades**



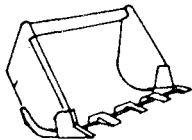
**Ripper Teeth Buckets**



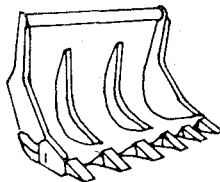
**Trapezoidal Buckets**



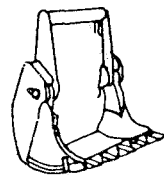
**Backhoe Ditching Buckets**



**Rehandling Buckets**

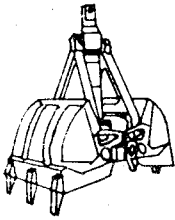


**Rock Shovel Buckets**

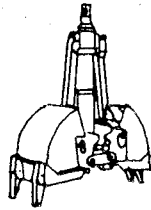


**Bottom-dump Shovel Buckets**

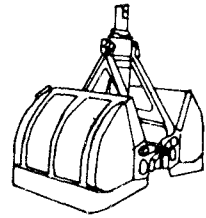
**Fig. 12.1 Attachments for Hydraulic Excavator**



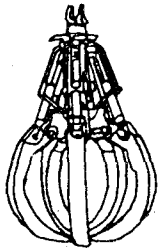
**Earth Moving Clams**



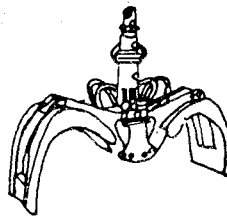
**Trenching Clamshells  
with Ejectors**



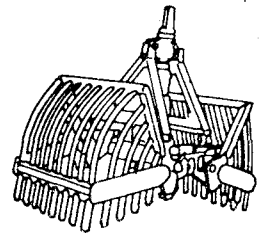
**Wide Rehandling Clams**



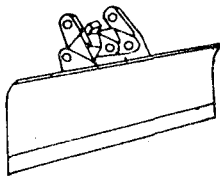
**Multiple Grapples**



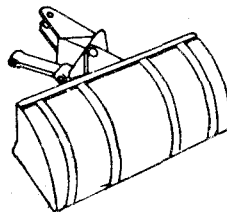
**Hydraulic Wood Grapples**



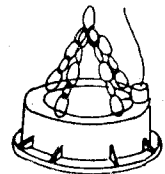
**Sugar Beet Grabs**



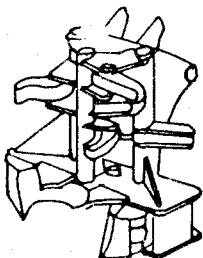
**Backfill Blades**



**Backhoe Grading Buckets**



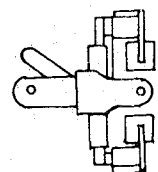
**Electro Magnets**



**Feller Buncher**



**Ripper Tooth**



**Post-hole Borer  
and Handling Clip**

**Fig. 12.2 : Attachments for Hydraulic Excavator**

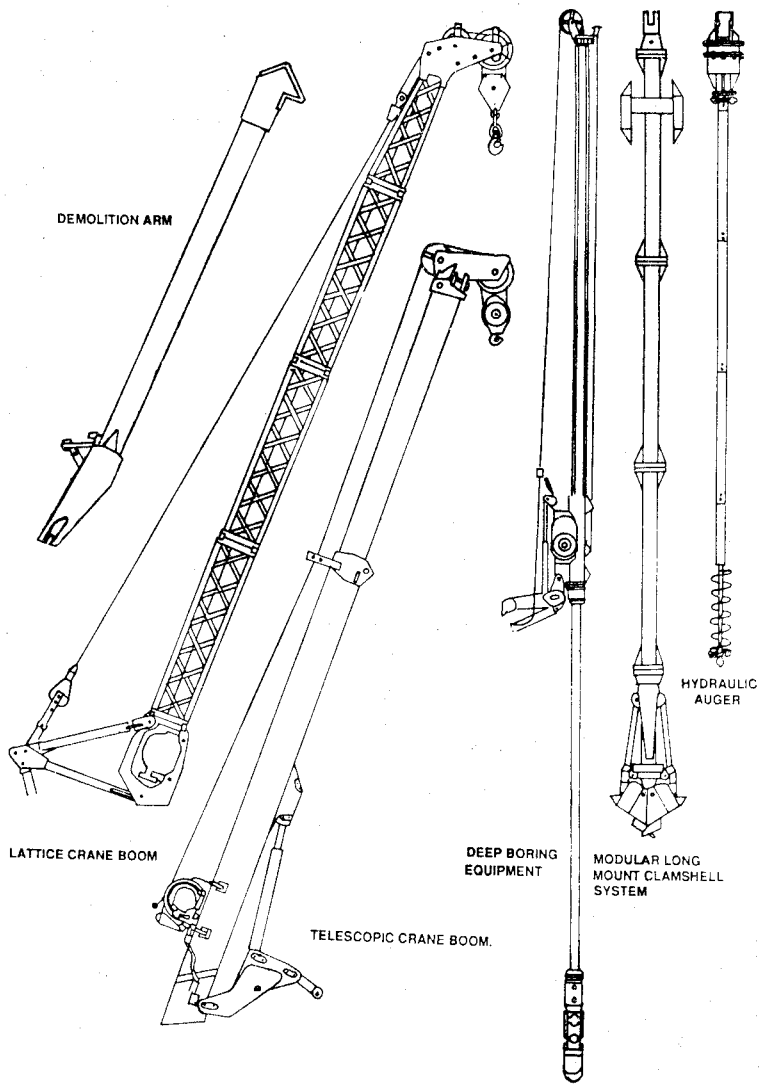


Fig. 12.3 : Attachment for Hydraulic Excavator

### **Above Ground Level - Applications :**

These are mainly done by using a shovel attachment, either bottom dumping or forward dumping. Applications are :

- Mining
- Quarrying
- Bulk earthmoving against face
- Tunneling

### **Under Ground Applications :**

These are generally handled by shovel or backhoe attachment or hydraulic hammers. Applications are :

- Tunnel making
- Excavation
- Scaling

### **Special Applications :**

By using special attachments, a hydraulic excavator can be used for other applications such as :

- Rock breaking, demolition.
- Wood handling (Forestry)
- General construction - vibratory pile drivers, extractors etc.
- Scrap handling.

### **Specialised Mounting Applications :**

Depending on work requirement, excavator can be -

- mounted on barge and pontoon for swamp, river and marine excavation or dredging operations.
- mounted on railcar for route maintenance activity of railway tracks.

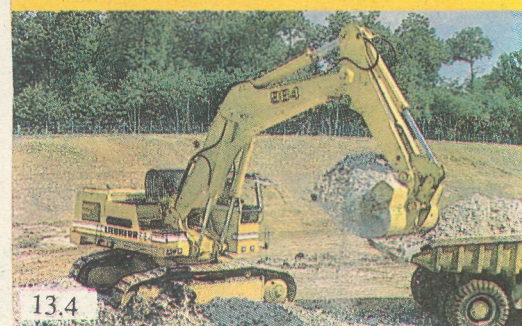
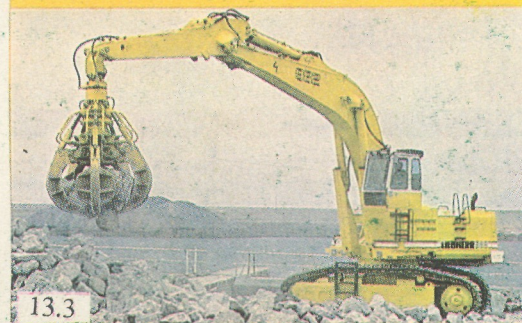
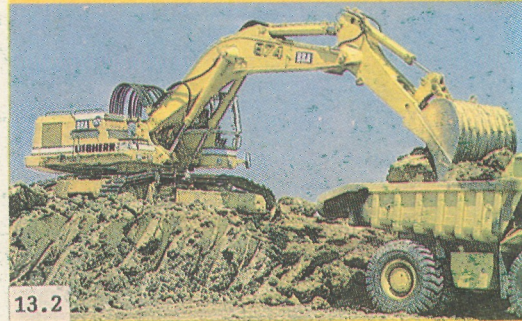
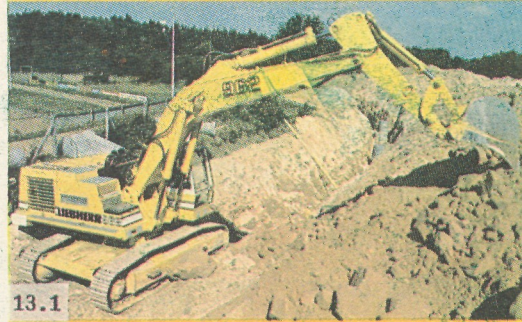


Explanation to the Figures

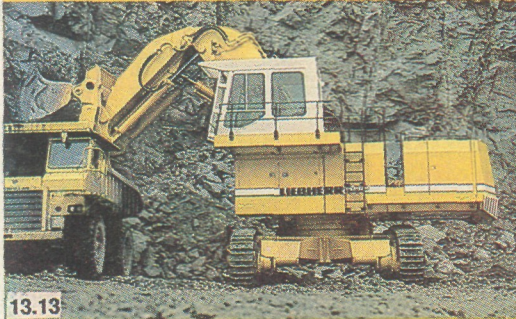
Figure 13

1. Excavation Applications  
(From Fig. 13.1-13.4 )
2. Open Pit Mining  
(From Fig. 13.12-13.15)
3. Quarries  
(From Fig. 13.16-13.19)
4. Special Applications  
(From Fig. 13.20-13.23)
5. Underwater Excavation  
(From Fig. 13.24-13.27)

**Excavation Applications**



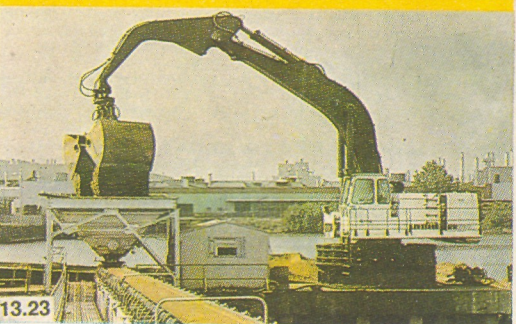
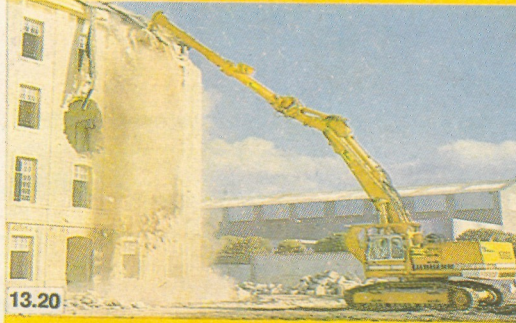
## Open Pit Mining



## Quarries



## Special Applications



## Underwater Excavation

